



## SIMULATION OF SHORT CIRCUIT CONDITION AND FAULT ANALYSIS IN POWER SYSTEM

Pooja<sup>1</sup> and Dr. Anand Kumar<sup>2</sup>

<sup>1</sup>Research Scholar Dept. Of Physics Singhania University Rajasthan.

<sup>2</sup>Associate Professor, Dept. Of Physics, All India Jat Heroes Memorial College, Rohtak.

### ABSTRACT:

This paper presents the short circuit Analysis of a Power System by Conventional methods and also presents review of the research work which had been done in field of Short Circuit Analysis. The steady state operating mode of a power system is balanced 3 phase ac. However, due to sudden external or internal changes in the system, this condition is disrupted. When the insulation of the system fails at one or more points or a conducting object comes in contact with a live point, then short circuit or fault occurs. As power lines are heavily interconnected to the systems. So fault analysis is very important for stability analysis. The one section faults will cause serious effects to other sections also. This idea has been analysis through this paper. The paper shows the complete study work and literature survey of Conventional Short Circuit Analysis methods, Different elements of the power system network, Different Faults occurring in Power System and severity of various Power System Faults. As we know that relay circuit has detects the faults and give the tripping signals to the circuit breakers and circuit breakers open the faulty line from healthy lines but sometimes it requires delay that system will balanced by itself, but here we see that within delay timing this fault will effects other lines also and voltage will decrease from there rated conditions. So we must need to improve and analysis whole system to maintaining reliable supply to other lines.

**KEY WORDS:** circuit Analysis , sudden external.

### I.INTRODUCTION:

is necessary to disconnect the faulted part from the healthy system as soon as possible. This is done by the circuit breaker and protective relay. Circuit breakers are usually installed at both ends of the transmission lines. The relay detects the fault occurs in its protection zone of the transmission line and then it will trip the circuit breakers of that line to open. This way, the faulted line will be separated from the healthy line of the

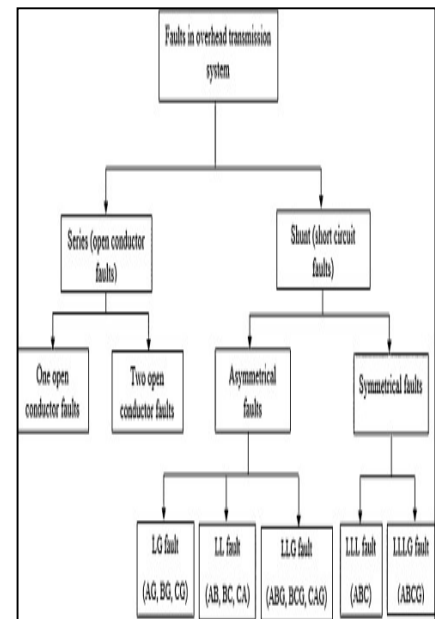

power system avoiding further damage. Shortly after the breaker operation, the relay will try to re-close the circuit breaker. If the fault is cleared, then the circuit breaker will successfully close the line with the remain healthy lines of the transmission system [1]. We choose the three phase to ground fault for our studies as this fault is the most severe among the faults and provides the worst case for the calculation of the circuit breaker ratings. When a fault occurs in the system very high level of current flows in the system making it very dangerous for the system and if adequate protection is not taken at correct time then the results will severe both for the system and the consumers. Symmetrical Faults or Three Phase to Ground Fault, refers to those conditions when all the three phases of the system are grounded at the same time [2]. These types of faults are mainly caused due to insulation failure and lightning stroke. Though symmetrical faults are rare, it leads to most severe fault current to flow in the system and may cause heavy damages to equipment. Therefore, short circuit analysis is performed to protect the system from any damage and limit the flow of current in the system. Short circuit analysis is done to determine the proper choice of protective devices, select efficient interrupting equipment and verify the adequacy of the existing interrupting equipment. The analysis before the fault is carried out by solving non-linear load flow problem by using numerical iterative technique of Newton-Raphson method. State estimation after short circuit fault is carried by using algorithm of short circuit current computation. The short circuit currents dictate the rating of circuit breakers to be employed at various buses and in various lines of the network. The effect of three phase short circuit faults on power system has been studied in terms of post-fault conditions and pre-fault conditions.

## II. SYSTEM EQUIPMENTS

### A. Buses

The term bus is very important in the analysis of power systems. Derived from the Latin omnibus (for all) the bus bar is literally a bar of metal to which all the appropriate incoming and outgoing conductors are connected. To be more precise, the bus bar consists of three separate bars, one for each phase. Called bus for short, it provides a reference point for measurements of voltage, current, and power flows. Various factors affect the reliability of a substation or switchyard, one of which is the arrangement of the buses and switching devices [1]. In addition to reliability, arrangement of the buses/switching devices will impact maintenance, protection, initial substation development, and cost. For load flow studies it is assumed that the loads are constant and they are defined by their real and reactive power consumption. It is further assumed that the generator terminal voltages are tightly regulated and therefore are constant. The main objective of the load flow is to find the voltage magnitude of each bus and its angle when the powers generated and loads are pre-specified. To facilitate this here classification of different buses [1] of the power system is shown in the chart below.

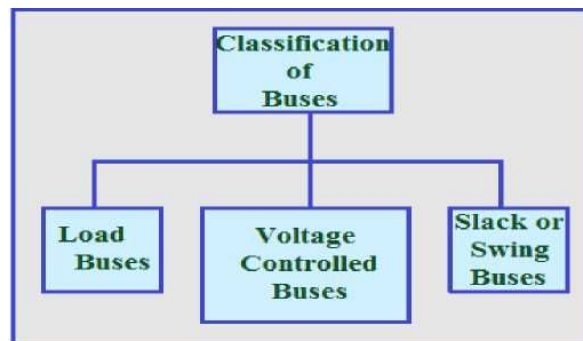

Fig. 1: Classification of Busses

### **B. Transmission Line**

Transmission Lines and distribution lines typically consist of aluminum, which is lightweight and relatively inexpensive, and are often reinforced with steel for strength. Stranded cable is often used, which, as the name suggests, is twisted from many individual strands. At the same diameter or gauge, stranded cable is much easier to bend and manipulate. For underground lines, cables with insulation are used. Here heat dissipation is more of an issue, whereas weight is not. Copper is the material of choice for underground cables because, while it is more expensive, it has a lower resistance than aluminum. Low resistance is generally desirable for power lines to minimize energy losses, but also because heating limits the conductor's ability to carry current.

### **C. Transformers**

A transformer is a device for changing the voltage level in an a.c. circuit with constant frequency. It basically consists of two conductor coils that are connected not electrically but through magnetic flux. As a result of electromagnetic induction, an alternating current in one coil will set up an alternating current in the other. However, the comparative magnitude of the current and voltage on each side will differ according to the geometry, that is the number of turns or loops in each coil. Transformers are of basically two types 1st. Step-Up (Voltage increases on secondary side) and 2nd. Step-Down (Voltage Decreases on Secondary Side)

### **D. Generator**

An electric generator is a device designed to take advantage of electromagnetic induction in order to convert movement into electricity. The electric generators can be classified in C Generators and A.C Generators. A.C generators are of two types Synchronous Generators and Induction. Of These types generators synchronous generators are highly recommended generators.

### **E. Synchronous Generators**

Synchronous Generators converts mechanical power to ac electric power with constant speed and hence frequency is constant. The source of mechanical power, the prime mover, may be a diesel engine, a steam turbine, a water turbine, or any similar device. Synchronous generators are built in large units, their rating ranging from tens to hundreds of megawatts.

### **F. Circuit Breakers**

A circuit breaker is defined as "a mechanical switching device capable of making, carrying and breaking currents under normal circuit conditions and also making, carrying and breaking for a specified time, and breaking currents under specified abnormal circuit conditions such as a short circuit". Circuit breakers are generally classified according to the interrupting medium used to cool and elongate the electrical arc permitting interruption. The types are Air magnetic, oil, air blast, vacuum and SF6 Gas.

## **III. DEFINITIONS**

### **A. Short Circuit Analysis**

A short circuit sometimes abbreviated to short or s/c is an electrical circuit that allows a current to travel along an unintended path, often where essentially no or a very low electrical impedance is encountered. The electrical opposite of a short circuit is an "open circuit", which is an infinite resistance between two nodes. It is common to misuse "short circuit" to describe any electrical malfunction, regardless of the actual problem.

### B. Load Flow Analysis

Power flow analysis is concerned with describing the operating state of an entire power system, by which we mean a network of generators, transmission lines, and loads that could represent an area as small as a municipality or as large as several states. Given certain known quantities, typically, the amount of power generated and consumed at different locations, powerflow analysis allows one to determine other quantities (i.e. bus Voltage Magnitude  $|V|$ , Power Angle  $\delta$ , Real Power Flow  $P$  and Reactive Power Flow  $Q$ ).

#### Contingency Analysis

Contingency Analysis actually provides and prioritizes the impacts on an electric power system when problems occur. A contingency is the loss or failure of a small part of the power system e.g. a transmission line, or an individual equipment failure such as a generator or transformer. This is also called an unplanned "outage". Contingency analysis is a computer application that uses a simulated model of the power system, to evaluate the effects, and calculate any overloads resulting from each outage event. In other word, Contingency Analysis is essentially a "preview" analysis tool that simulates and quantifies the results of problems that could occur in the power system in the immediate future.

**IV. SOFTWARE ANALYSIS** At first we have taken IEEE14 Bus system in Mat lab Simulink by drawing each area in subsystem block or with proper data's which are used for IEEE 14 bus system.

In this Simulink model each subsystem contains a power system network, which is similar as the real power network (Fig3) after drawing Simulink diagram we have tested its data in different ways, which are illustrated in the next page in different case study.

### IEEE 14 BUS POWER SYSTEM MATLAB MODEL ANALYSES

This system is consists of 14 no of sub system. each of these sub system is consists of two individual systems each of the system consists of one programmable 3 phase source of 11000 RMS line voltage one 3 phase RLC line and one 3 phase RLC load of 100 watt active power and 100 lagging VAR and 100 leading VAR and a 3 phase VI measurement block. Each of this system is connected by a 3 phase RLC line. In the 3,4,5,6,7,8,9,10,11,12 and 13 number subsystem there is a 100 leading VAR (Capacitor) which is connected with 3-phase line to improve the voltage stability and also to improve the power factor. The 12th and 13th no subsystem there are two numbers of RL of 100 w active power and 100 lagging VAR reactive power are connected. In the 1st & 2nd no of subsystem there is a 3 phase fault is occurred in the intermediate line between the two 3 phase lines of each system. There is a circuit breaker is connected between the 3 phase RLC load and the line in each block. There is a VI measurement block is connected between the circuit breaker and the 3 phase RLC load to measures the output result. These four steps are analysis following ways.

**THE FAULTY SUBSYSTEM-1 & SUBSYSTEM-2 MATLAB MODEL** At first we take the healthy power network and analyzing the network voltage, current for stability analysis. We observed the curves of voltage and current, which are nearly maintained.

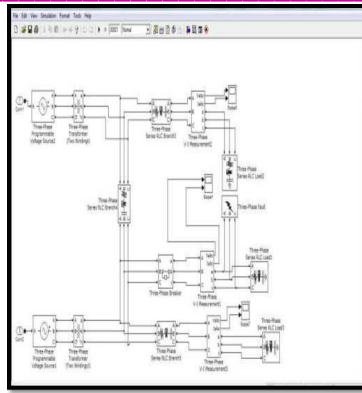

Figure 3 Power network in IEEE 14 bus network

#### IV. FAULT ANALYSIS THE FAULTY SUBSYSTEM 1 & SUBSYSTEM 2 MATLAB MODEL ANALYSIS

In both of subsystem1 and subsystem2 model let a three phase ground fault has occurred and the circuit breaker is capable to clear the fault's, our power system lines are heavily interconnected so one line fault will affect the other transmission lines also which are not desirable at all, because others bus voltages are affected which we can concluded by analyzing outputs of different subsystems. Where we saw that the output had one positive sequence phase voltage and current where there are another two negative sequence phase voltage and current wave formed which are find out in the voltage measuring scopes to the network. The outputs are others bus or areas and decreases or increases the voltage and current levels. Which are highly undesirable because the power systems faults are occurred suddenly, so if one area load is highly sophisticated than other area but due to irrelevant fault for one area or line will creates major or minor faults to others load area and breaks the reliability conditions, even this small fault creates a huge problem or fault in distribution company. So major area will be blackouts or voltage instability occurred.



Figure 5 when fault occurred in subsystems, the other bus voltages and current waveforms We can concluded that one bus or one area fault will affect

#### V. CONCLUSION

From the above discussion of IEEE 14 bus power system Mat-Lab model we can conclude that in an interconnected electrical power system if there is a fault occurs in any of the subsystem , all the system voltages and system currents are affected and must be improved otherwise it will creates fault of circuit parameters to

other lines. This paper presents the Research literature work and the Review about the Short Circuit Analysis of a large Power System Network. Survey and lot of research papers have been presented for the improvement and new methods to analyze the Short Circuit Calculation in a Power System. The Aim of this Review Paper is to propose a calculation method in effortless technique for Short Circuit Analysis. The analysis of the most serious short-circuit fault provides a very high inrush current which is very dangerous for the system so to chop- out this shown in Figure-5. heavy current, a suitable step should be taken so that the dangerous effects of symmetrical faults can diminish and making the system more reliable. If we will not improve or disconnected faulty lines or area from healthy lines or area then huge crisis of power will be occurred, even blackouts. So instability, transient stability, fault analysis are very important in power network.

## REFERENCES

- [ 1 ] [http://en.wikipedia.org/wiki/Short\\_circuit](http://en.wikipedia.org/wiki/Short_circuit)
- [2] Pushp Raj (2013), Load Flow and Short Circuit Analysis of 400/220kv Substation, International Journal of Creative Research Thoughts, Volume1, Issue.4.
- [3] Jin Yang (2011), Short Circuit and Ground Fault Analysis and Location in VSC-Based DC Network Cables, IEEE
- [4] Alexandra Von Meier Whose Book "Electric Power Systems a Conceptual Introduction" 2006 by John Wiley & Sons, Inc.
- [5] C.L.WADHWA Load flows, Chapter 18, Bus classification, Comparison of solution methods, NR Method- Electrical Power system New Age international publishers
- [6] Debapriya Das, Electrical Power systems New Age international publishers New Dehli. SHORT CIRCUIT ANALYSIS BY USING MIPOWER Pranshu Shrivastava, Shweta Sahu Modi, Pooja Shrivastava Pro term Lecturer in Electrical department of IITM Gwalior Asst Prof in Electrical department of IITM Gwalior Pro term Lecturer in Maths department of ITM University Gwalior International Journal of Engineering Research and Applications (IJERA) ISSN: 22489622 International Conference On Emerging Trends in Mechanical and Electrical Engineering (ICETMEE- 13th-14th March 2014).
- [7] Jadeepsinh.C.Barua, Viral.S. Chaudhari, Paresh S. Chaudhari and Y.R. Prajapati (2011), Short Circuit Analysis of Realistic Application for Modeling of Power System using MiPower Software, National Conference on Recent Trends in Engineering and Technology.
- [8] Debniloy De, Shivanjali A. Mishra, Aditya Kar and Sheila Mahapatra, Short Circuit Analysis of a Power Grid using MiPower Software EECE, ITM University, Gurgaon, Haryana, INDIA.
- [9] Renuka Kamdar, Mukesh Kumar Kirar, Manoj Kumar, Ganga Agnihotri Short Circuit Analysis of an Industrial Distribution System Department of Electrical Engineering, MANIT, Bhopal, India Proc. of the Second Intl. Conf. on Advances in Computer, Electronics and Electrical Engineering -- CEEE 2013.
- [10] Daljeet Kaur, Dr. S.K.Bath, Darshan Singh Sidhu Short Circuit Fault Analysis of Electrical Power System using MATLAB IOSR Journal of Electrical and Electronics Engineering (IOSR-JEEE) e-ISSN: 2278-1676, p-ISSN: 2320-3331, Volume 9, Issue 2 Ver. III (Mar - Apr. 2014), PP 89-100 [www.iosrjournals.org](http://www.iosrjournals.org).
- [11] Jan Machowski, Janusz W. Bialek, James R. Bumby POWER SYSTEM DYNAMICS Stability and Control 2008 John Wiley & Sons, Ltd.